1322x-Low Power Node (1322x-LPN)

Reference Manual

Document Number: 1322xLPNRM
Rev. 1.2
09/2008



How to Reach Us:

Home Page:
www.freescale.com

E-mail:
support@freescale.com

USA/Europe or Locations Not Listed:
Freescale Semiconductor
Technical Information Center, CH370
1300 N. Alma School Road
Chandler, Arizona 85224
+1-800-521-6274 or +1-480-768-2130
support@freescale.com

Europe, Middle East, and Africa:
Freescale Halbleiter Deutschland GmbH
Technical Information Center
Schatzbogen 7
81829 Muenchen, Germany
+44 1296 380 456 (English)
+46 8 52200080 (English)
+49 89 92103 559 (German)
+33 1 69 35 48 48 (French)
support@freescale.com

Japan:
Freescale Semiconductor Japan Ltd.
Headquarters
ARCO Tower 15F
1-8-1, Shimo-Meguro, Meguro-ku,
Tokyo 153-0064, Japan
0120 191014 or +81 3 5437 9125
support.japan@freescale.com

Asia/Pacific:
Freescale Semiconductor Hong Kong Ltd.
Technical Information Center
2 Dai King Street
Tai Po Industrial Estate
Tai Po, N.T., Hong Kong
+800 2666 8080
support.asia@freescale.com

For Literature Requests Only:
Freescale Semiconductor Literature Distribution Center
P.O. Box 5405
Denver, Colorado 80217
1-800-521-6274 or 303-675-2140
Fax: 303-675-2150
LDCForFreescaleSemiconductor@hibbertgroup.com

Information in this document is provided solely to enable system and software implementers to use Freescale Semiconductor products. There are no express or implied copyright licenses granted hereunder to design or fabricate any integrated circuits or integrated circuits based on the information in this document.

Freescale Semiconductor reserves the right to make changes without further notice to any products herein. Freescale Semiconductor makes no warranty, representation or guarantee regarding the suitability of its products for any particular purpose, nor does Freescale Semiconductor assume any liability arising out of the application or use of any product or circuit, and specifically disclaims any and all liability, including without limitation consequential or incidental damages. "Typical" parameters that may be provided in Freescale Semiconductor data sheets and/or specifications can and do vary in different applications and actual performance may vary over time. All operating parameters, including "Typicals", must be validated for each customer application by customer's technical experts. Freescale Semiconductor does not convey any license under its patent rights nor the rights of others. Freescale Semiconductor products are not designed, intended, or authorized for use as components in systems intended for surgical implant into the body, or other applications intended to support or sustain life, or for any other application in which the failure of the Freescale Semiconductor product could create a situation where personal injury or death may occur. Should Buyer purchase or use Freescale Semiconductor products for any such unintended or unauthorized application, Buyer shall indemnify and hold Freescale Semiconductor and its officers, employees, subsidiaries, affiliates, and distributors harmless against all claims, costs, damages, and expenses, and reasonable attorney fees arising out of, directly or indirectly, any claim of personal injury or death associated with such unintended or unauthorized use, even if such claim alleges that Freescale Semiconductor was negligent regarding the design or manufacture of the part.

ARM is the registered trademark of ARM Limited. ARM7TDMI-S is the trademark of ARM Limited.

Freescale™ and the Freescale logo are trademarks of Freescale Semiconductor, Inc. All other product or service names are the property of their respective owners.

© Freescale Semiconductor, Inc. 2005, 2006, 2007, 2008. All rights reserved.

Contents

About This Book

Audience	iii
Organization	iii
Revision History	iii

Chapter 1 Safety Information

1.1	FCC Guidelines.	1-1
1.2	FCC Labeling	1-1
1.2.1	47 C.F.R. Sec. 15.21	1-1
1.2.2	47 C.F.R. Sec.15.105(b)	1-2
1.2.3	47 C.F.R. Sec.15.203	1-2
1.3	Regulatory Approval For Canada	1-2
1.4	Disposal Instructions.	1-2

Chapter 2 1322x-LPN Description

2.1	Introduction.	2-1
2.2	Features.	2-2
2.3	Board Level Specifications.	2-3

Chapter 3 System Overview and Functional Block Descriptions

3.1	System Block Diagram	3-1
3.2	Design Overview	3-1
3.2.1	1322x-LPN Form Factor.	3-3
3.3	RF 2.4 GHz ISM Band radio design.	3-4
3.4	Power Sources.	3-4
3.4.1	External DC Source	3-4
3.4.2	Battery Sources	3-5
3.4.3	Optional Use of MC1322x Buck Regulator	3-6
3.5	Clock Sources	3-7
3.5.1	Reference Oscillator (24 MHz nominal)	3-7
3.5.2	32.768 kHz Crystal Oscillator	3-8
3.6	FLASH Memory Recovery Jumpers and Erase	3-8
3.7	Low Power Operation.	3-9
3.7.1	Switched VCC for Peripheral Functions	3-9
3.7.2	Measuring Current	3-10
3.7.3	Other Low Power Considerations.	3-10
3.8	User Interfaces	3-11
3.8.1	LEDs, Switches, and Reset	3-11
3.8.2	ADC Voltage References	3-11

3.8.3	ARM JTAG Debug Interface Connector	3-12
3.8.4	GPIO Connector	3-12
3.8.5	UART Connector	3-13
3.8.6	Jumper Selection.	3-14

Chapter 4

Schematic, Board Layout, and Bill of Materials

About This Book

This manual describes Freescale's 1322x Low Power Node (1322x-LPN) evaluation board. The 1322x-LPN contains a Freescale third-generation, low power, 2.4 GHz radio frequency transceiver, with 32-bit ARM7 core based MCU, hardware acceleration for both the IEEE Standard 802.15.4 MAC and AES security, and a full set of MCU peripherals into a 99-pin LGA Platform-in-Package (PiP).

Audience

This manual is intended for system designers.

Organization

This document is organized into four chapters.

- Chapter 1 Safety Information — Describes that any modifications to this product may violate the rules of the Federal Communications Commission and make operation of the product unlawful.
- Chapter 2 1322x-LPN Overview and Description — Introduces the 1322x-LPN, which is an IEEE 802.15.4 compliant wireless node based on the Freescale MC1322x device.
- Chapter 3 System Overview and Functional Block Descriptions — This section provides an overview of the 1322x-LPN and its block diagram.
- Chapter 4 Schematic and Bill of Material — Contains the schematic, board layout, and bill of material (BOM).

Revision History

The following table summarizes revisions to this document since the previous release (Rev 1.1).

Revision History

Location	Revision
Entire document	Scrubbed for stale part number references.

Definitions, Acronyms, and Abbreviations

The following list defines the acronyms and abbreviations used in this document.

ADC	Analog to Digital Converter
AES	Advanced Encryption Standard
ARM	Advanced RISC Machine
CTS	Clear to Send
DAC	Digital to Analog Converter
DMA	Direct Memory Access
I2C	Inter-Integrated Circuit is a multi-master serial computer bus
ISM	Industrial Scientific Medical 2.4 GHz radio frequency band
JTAG	Joint Test Action Group
LGA	Land Grid Array
MAC	Media Access Controller
MCU	Microcontroller Unit
NEXUS	An embedded processor development tool interface that helps design engineers identify software and hardware-level issues.
SN	Sensor Node
pcb	Printed circuit board
PiP	Platform in Package
PWM	Pulse-width modulation
RTS	Request to Send
SMA Connector	Sub Miniature version “A” connector
SPI	Serial Peripheral Interface
SSI	Synchronous Serial Interface
TACT Switch	A switch that provides a slight “snap” or “click” to the user to indicate function.
TELCO	Telephone Company
USB	Universal Serial Bus
VCP	Virtual Com Port

Chapter 1

Safety Information

1.1 FCC Guidelines

This equipment is for use by developers for evaluation purposes only and must not be incorporated into any other device or system. This device may not be sold to the general public. Integrators will be responsible for reevaluating the end product (including the transmitter) and obtaining a separate FCC authorization.

FCC approval of this device only covers the original configuration of this device as supplied. Any modifications to this product, including changes shown in this manual, may violate the rules of the Federal Communications Commission and Industry Canada and make operation of the product unlawful.

1.2 FCC Labeling

FCC labels are physically located on the back of the board.

1.2.1 47 C.F.R. Sec. 15.21

This equipment has been tested and found to comply with the limits for a Class B digital device, pursuant to part 15 of the FCC Rules. These limits are designed to provide reasonable protection against harmful interference in a residential installation. This equipment generates, uses and can radiate radio frequency energy and, if not installed and used in accordance with the instructions, may cause harmful interference to radio communications. However, there is no guarantee that interference will not occur in a particular installation. If this equipment does cause harmful interference to radio or television reception, which can be determined by turning the equipment off and on, the user is encouraged to try to correct the interference by one or more of the following measures:

- Reorient or relocate the receiving antenna.
- Increase the separation between the equipment and receiver.
- Connect the equipment into an outlet on a circuit different from that to which the receiver is connected.
- Consult the dealer or an experienced radio/TV technician for help.

1.2.2 47 C.F.R. Sec.15.105(b)

This equipment complies with FCC radiation exposure limits set forth for an uncontrolled environment. The antenna(s) used for this equipment must be installed to provide a separation distance of at least 8 inches (20cm) from all persons.

This device complies with Part 15 of the FCC Rules. Operation is subject to the following three conditions:

1. This device may not cause harmful interference.
2. This device must accept any interference received, including interference that may cause undesired operation.
3. This device is susceptible to electrostatic discharge (ESD) and surge phenomenon.

1.2.3 47 C.F.R. Sec.15.203

An intentional radiator shall be designed to ensure that no antenna other than that furnished by the responsible party shall be used with the device. The use of a permanently attached antenna or of an antenna that uses a unique coupling to the intentional radiator shall be considered sufficient to comply with the provisions of this Section. The manufacturer may design the unit so that a broken antenna can be replaced by the user, but the use of a standard antenna jack or electrical connector is prohibited. This requirement does not apply to carrier current devices or to devices operated under the provisions of Sections 15.211, 15.213, 15.217, 15.219, or 15.221. Further, this requirement does not apply to intentional radiators that must be professionally installed, such as perimeter protection systems and some field disturbance sensors, or to other intentional radiators which, in accordance with Section 15.31(d), must be measured at the installation site. However, the installer shall be responsible for ensuring that the proper antenna is employed so that the limits in this Part are not exceeded.

1.3 Regulatory Approval For Canada

This Class B digital apparatus complies with Canadian ICES-003 and RSS 210, Issue 7.

Cet appareil numérique de la classe B est conforme à la norme NMB-003 du Canada.

1.4 Disposal Instructions

This product may be subject to special disposal requirements. For product disposal instructions, refer to www.freescale.com/productdisposal.

Chapter 2

1322x-LPN Description

2.1 Introduction

The 1322x-LPN is an IEEE 802.15.4 compliant wireless node based on the Freescale MC1322x device. The heart of the 1322x-LPN is Freescale's MC1322x 99-pin LGA Platform-in-Package (PiP) solution that can be used for wireless applications ranging from simple proprietary point-to-point connectivity to complete ZigBee mesh networking. The MC1322x is designed to provide a highly integrated, total solution, with premier processing capabilities and very low power consumption.

The 1322x-LPN provides a platform to evaluate the MC1322x device, develop software and applications, demonstrate IEEE 802.15.4 and ZigBee networking capabilities and implement low power operation. The small form factor illustrates a small footprint, 2-layer printed circuit board (PCB) layout with integrated printed-wire F-antenna. The LPB provides a GPIO connector to interface with application devices, a separate second unbuffered UART connector, and a full JTAG debug port connector.



Figure 2-1. 1322x-LPN

The 1322x-LPN is specifically intended as a prototype development platform for low power applications, use of the buck converter, 2-layer PCB design, use of the 32.768 crystal oscillator, and non-standard crystal reference oscillators (requiring PLL operation).

2.2 Features

The 1322x-LPN provides the following features:

- Full IEEE 802.15.4 compliant wireless node; ZigBee capable with Freescale's BeeStack software stack
- Based on Freescale's third-generation MC1322x ZigBee platform which incorporates a complete, low power, 2.4 GHz radio frequency transceiver, 32-bit ARM7 core based MCU, hardware acceleration for both the IEEE 802.15.4 MAC and AES security, and a full set of MCU peripherals into a 99-pin LGA Platform-in-Package (PiP)
- MC1322x provides a highly integrated, low cost RF node
 - On-board balun and antenna switch in package
 - Typical -95 dBm sensitivity
 - Typical 0 dBm output power, with max approximately +4 dBm
 - F-antenna
- Standard JTAG debug/development interface connector
- Power management circuit with on-board regulation for multiple power sources
 - Can be powered from DC power jack, two AAA batteries, or optional Lithium coin cells
 - On/Off power switch
 - Optional header for measuring MC1322x current
 - Power-on green LED
- Supports optional use of buck converter
- User interface switches and LEDs
 - 2 push buttons for application purposes
 - 2 processor controlled red LEDs for application purposes
 - Header for hardware reset
- User interfaces include
 - 12-pin GPIO connector provides access to ADC inputs, unbuffered UART2 port, I2C port, and KBI pins (provide wake-up capabilities from low power)
 - 6-pin UART connector provides access to second unbuffered UART1 port
- System clock options
 - Default 24 MHz crystal reference oscillator. Supports use of PLL with non-default 13-26 MHz crystal.
 - Optional 32.768 kHz crystal oscillator for accurate real-time delays (crystal is mounted).
- Fixed 1.5 V reference for ADC VREFH during battery operation
- Separate switched VCC (via P-channel MOSFET) for power control of off-chip peripheral functions.

2.3 Board Level Specifications

Table 2-1. 1322x-LPN Specifications

Parameter				Units	Notes/Conditions
	MIN	TYP	MAX		
General					
Size (Enclosure: X, Y, Z)			74x56x37	mm	
Size (PCB: X, Y)			65x45	mm	
Layer build (PCB)		0.8 / 0.032		mm / in	2-Layer
Dielectric material (PCB)					FR4
Power					
Voltage supply (DC)	4.4	5	12	V	
Voltage supply (Batteries)	2.0	3	3.6	V	
Current consumption			55	mA	
Temperature					
Operating temperature	-30	+25	+85	°C	
Storage temperature	-30	+25	+85	°C	
RF					
Frequency range	2405		2480	MHz	All 16 channels in the 2450 MHz band, 5 MHz spacing
Range (outdoor / line of sight)		300		Meter	<1% PER for 20-byte packets (point-to-point in communications with 1322X Sensor Reference Board)
RF Transmitter					
802.15.4 Output power	-30	0	+4	dBm	Over range of Pout from IC control in 2 dB steps. Note: On channel 26, output power should not exceed -5.5 dBm (Power setting 0x0E) to meet FCC part 15 requirements.
Harmonics 2 nd harmonics 3 rd harmonics			-38 -35	dBm dBm	Harmonics are compliant to ETSI and FCC regulatory approval standards
RF Receiver					
Sensitivity		-95		dBm	<1% PER for 20-byte packets
Regulatory Approval					
FCC					Product complies accordingly to the FCC part 15 standard

Table 2-1. 1322x-LPN Specifications (continued)

Parameter				Units	Notes/Conditions
CE (ETSI)					Product complies accordingly to the EN 300 328 V1.7.1 (2006-10) standard
CE (EMC)					Product complies accordingly to the EN 301 489-1 V1.6.1 (2005-09) and EN 301 489-17 V1.2.1 (2002-08) standards
Safety					
UL					Product complies accordingly to the IEC 60950-1 and EN 60950-1, First Edition standards
Environment					
RoHS					Product complies with the EU Directive 2002/95/EC of 27 January 2003
WEEE					Product complies with the EU Directive 2002/95/EC of 27 January 2003

Chapter 3

System Overview and Functional Block Descriptions

This section provides an overview of the 1322x-LPN and its block diagram.

3.1 System Block Diagram

The following is the 1322x-LPN system level block diagram.

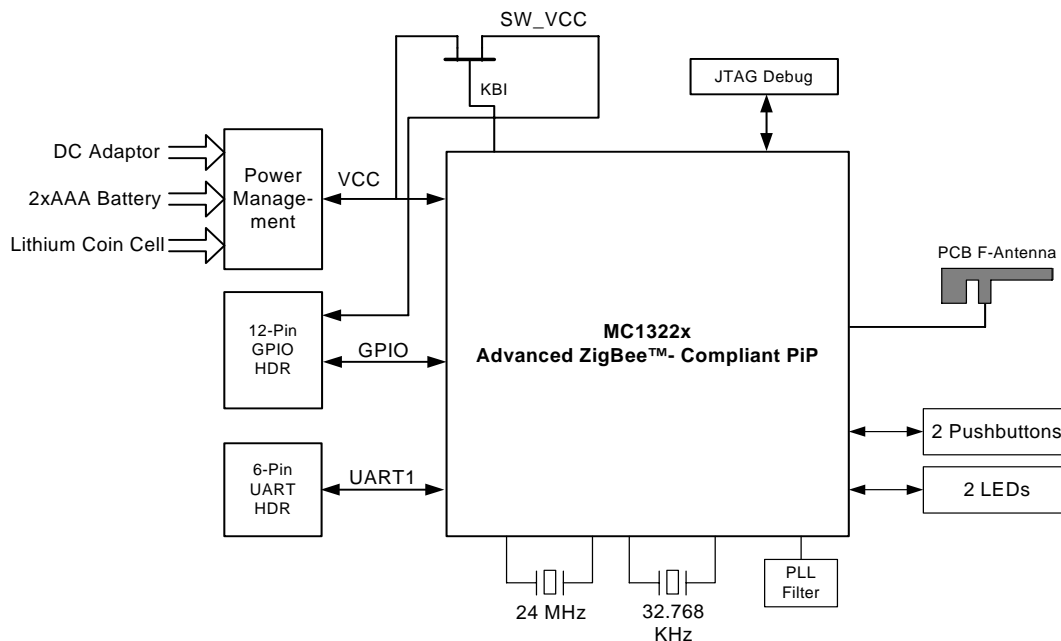

Figure 3-1. 1322x-LPN Block Diagram

3.2 Design Overview

The heart of the 1322x-LPN is Freescale's MC1322x 99-pin LGA Platform-in-Package (PiP) solution that can be used for wireless applications ranging from simple proprietary point-to-point connectivity to complete ZigBee mesh networking. The main attributes of the 1322x-LPN module are:

- Small footprint with a 2-layer PCB and F-antenna
- Support for very low power operation
- Support for Lithium coin cell operation
- Support for optional buck converter
- Support for 32.768 KHz crystal oscillator
- Support for non-standard reference oscillator crystal (13-26 MHz and requires use of PLL filter)

The MC1322x MCU resources offer superior processing power for ZigBee and IEEE 802.15.4 applications. A full 32-bit ARM7TDMI-S core operates up to 26 MHz. A 128 Kbyte FLASH memory is mirrored into a 96 Kbyte RAM for upper stack and applications software. In addition, an 80 Kbyte ROM is available for boot software, peripheral device drivers, standardized IEEE 802.15.4 MAC and communications stack software. A full set of peripherals and Direct Memory Access (DMA) capability for transceiver packet data complement the processor core.

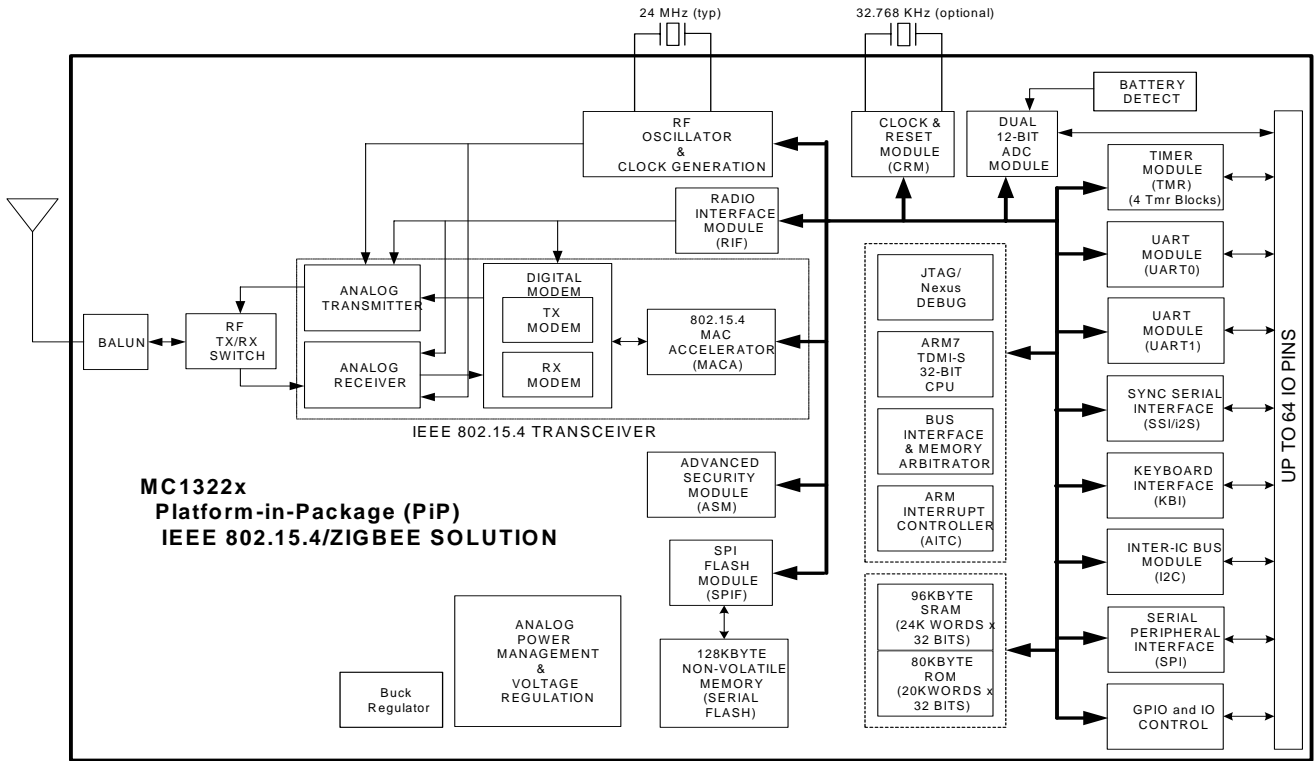

Figure 3-2. MC1322x Block Diagram

The RF radio interface provides for low cost and high density as shown in Figure 3-3. An onboard balun along with a TX/RX switch allows direct connection to a single-ended 50-Ω antenna. The integrated PA provides programmable output power typically from -30 dBm to +4 dBm, and the RX LNA provides -95 dBm sensitivity. This solution also has onboard bypass capacitors and crystal load capacitors for the smallest footprint in the industry. All components are integrated into the package except the crystal and antenna.

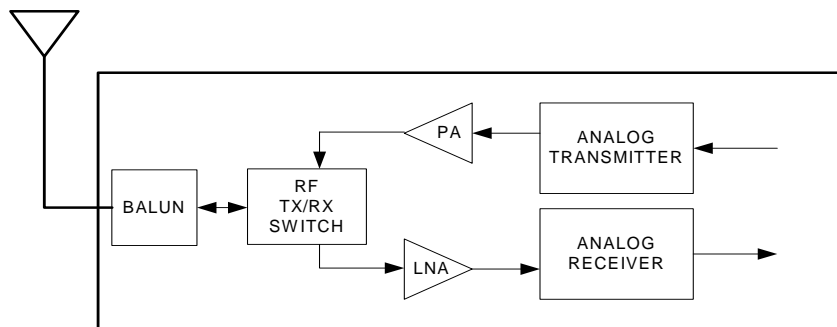

Figure 3-3. MC1322x RF Interface

3.2.1 1322x-LPN Form Factor

The MC1322x allows for very small footprint applications. The 1322x-LPN circuit board illustrates a small footprint for the MC1322x/RF area and use of a 2 metal layer design. This board can be used as a template for a 2-layer PCB design (design files are available), or additional reference designs are available at freescale.com/zigbee.

Freescale provides a one-stop-shop approach to guide customers with their wireless solutions to help minimize product time-to-market. One important recommendation is to follow the layout application guide as described in the *Freescale IEEE 802.15.4 / ZigBee Package and Hardware Layout Considerations Reference Manual (ZHDCRM)*. This manual describes Printed Circuit Board (PCB) footprint guidelines for the MC1322x LGA 71 package. Included are layouts of the component copper layer, solder mask, and solder paste stencil.

Figure 3-4 shows the 1322x-LPN PCB top view. Refer to this figure when reviewing the following sections.

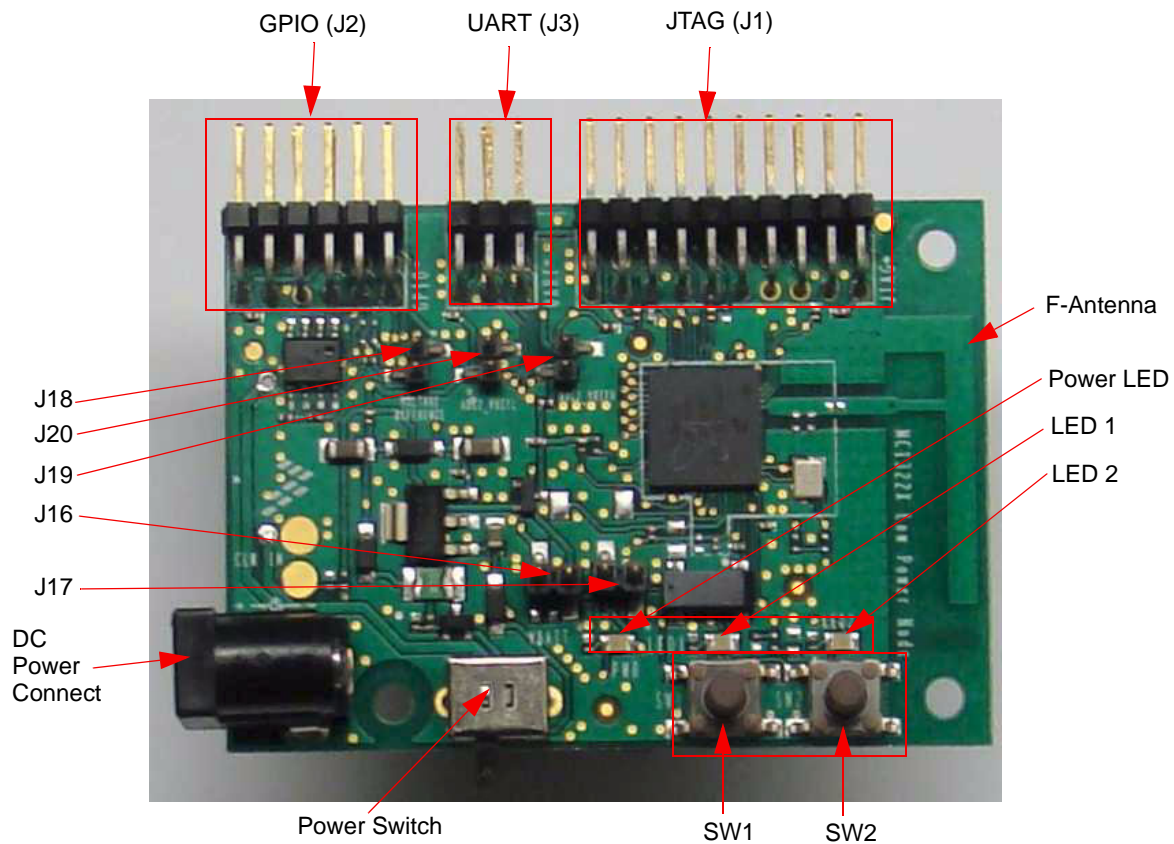

Figure 3-4. 1322x-LPN PCB Top View

3.3 RF 2.4 GHz ISM Band radio design

The MC1322x transceiver includes a low noise amplifier, 1mW nominal output power, PA with internal voltage controlled oscillator (VCO), integrated transmit/receive switch, on-board power supply regulation, and full spread-spectrum encoding and decoding. The 1322x-LPN requires only a minimum amount of external components and a chip-antenna for a complete solution. Figure 3-5 shows the RF network external to the MC1322x.

- Typical nominal output power is 0 dBm, with +4 dBm max
- Typical sensitivity is -95 dBm.
- Frequency range is 2405 to 2480 MHz
- Typical range (outdoors, line of sight) is 300 meters
- Uses a minimum number of RF components

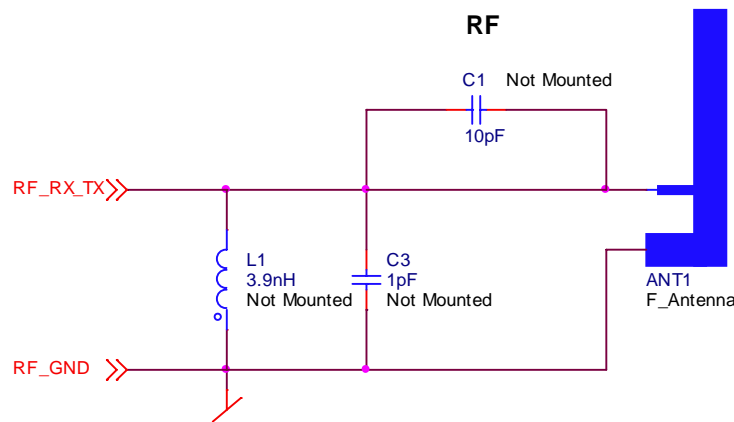

Figure 3-5. 1322x-LPN RF Network.

3.4 Power Sources

To allow maximum versatility, the 1322x-LPN can be powered via a DC source (nominally 5 VDC) or a variety of battery sources.

- An “OFF/ON” slide switch (SW5) is provided that disconnects all supplies, no matter which is active.
- A green “PWR” LED (D5) is provided as a Power-On indicator.
- All sources are isolated via diodes.

3.4.1 External DC Source

The DC source is typically an AC-DC converter

- The DC source can be from 4.4 to 12 VDC
- When connected, it automatically shuts down the battery supply.
- The DC source is regulated to 3.3 V; however, the raw battery pack voltage directly supplies the circuitry

3.4.2 Battery Sources

The battery source can be either a AAA battery pack (2 cells) or an optional Lithium coin cell:

- AAA source - as supplied, the 1322x-LPN has a 2-cell AAA battery holder mounted. The typical usable voltage range for 2 AAA cells is ~3.1V down to 2.2 - 2.0V. Note that a Schottky diode and a switch MOSFET are in series with the battery pack, and these will impact the lowest usable voltage for the battery pack.
- Lithium coin cell source - in some very low duty cycle applications where the system mostly “sleeps” in low power, the use of a Lithium coin cell can be considered. To assist in this design, the 1322x-LPN supports mounting a socket for a coin cell
 - The AAA battery holder must first be removed.
 - Mount one of two sockets for a Lithium coin cell
 - Renata #SMTU2477N-1 - SMD holder for CR2477N cell (950 mAh)
 - Renata #SMTU2450N-1 - SMD holder for CR2450N cell (540 mAh)
 - The bottom view of the 1322x-LPN is shown in [Figure 3-6](#).
 - The mounting pads for the socket are noted (both sockets use the same pads). Be sure to observe proper polarity.
 - The mounting pads for two 100µF tantalum capacitors (C59 & C60) are also provided.

NOTE

Designing with Manganese Dioxide Lithium Coin Cell technology can be very challenging. It is recommended to consider the following:

- Source impedance is high, typically about 25 ohms. Consider the fluctuation in source voltage under heavy current load (~20 mA or more).
- The addition of heavy bulk capacitance (such as C59 & C60) on VCC can help minimize voltage drop under heavy current.
- High current duty cycle is critical; every effort must be made to minimize high current activity (primarily TX and RX).
- When developing a coin cell application, it is highly recommended to use the external DC source for all code development and early testing. Life of coin cells can be very short with continual and/or heavy load.

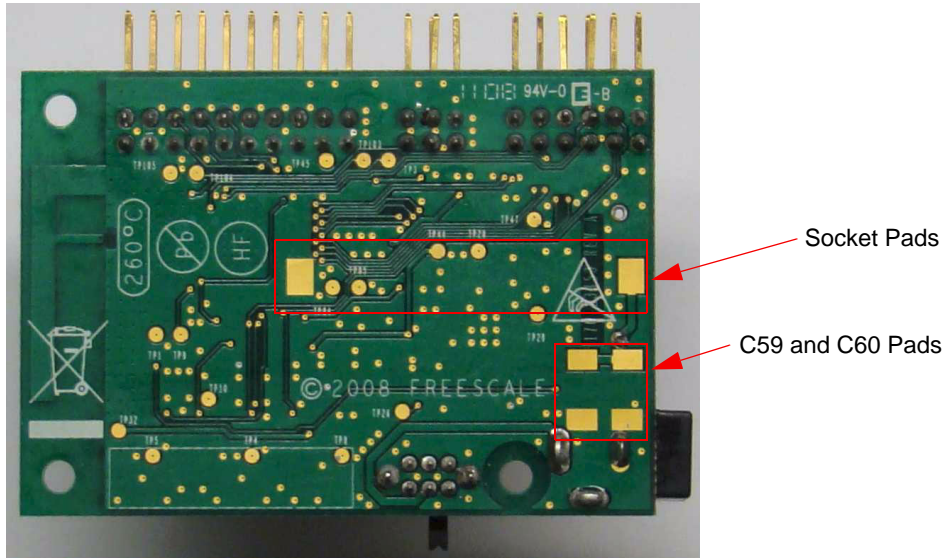

Figure 3-6. 1322x-LPN PCB Bottom View

3.4.3 Optional Use of MC1322x Buck Regulator

The MC1322x is typically used in a single source, unregulated VCC configuration (VBATT connected in parallel with LREG_BK_FB), and the 1322x-LPN is supplied in this connection. However, the MC1322x also has an optional buck switched regulator, and the 1322x-LPN supports use of the buck function.

Figure 3-7 shows the VCC connection at the MC1322x device. The PCB is supplied with the 0-ohm R66 component mounted, which is the simple non-regulated configuration. To allow use of the buck regulator:

- Remove R66
- Mount L2; an SMD power 100uH inductor, from manufacturer TDK # SLF6028T-101MR42-PF (see Chapter 4, “Schematic, Board Layout, and Bill of Materials”).
- Mount C52; a 100 μ F ceramic capacitor.

NOTE

Use of the buck converter requires proper initialization, control and support through the application software. Refer to the *MC1322x Reference Manual*.

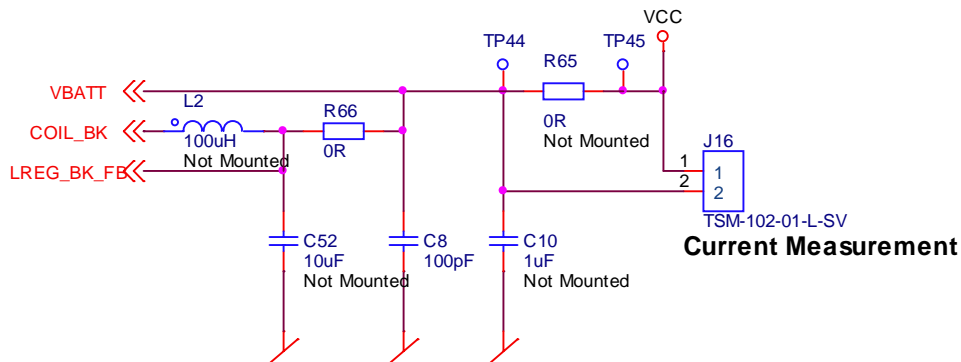

Figure 3-7. MC1322x Main Power Connection

3.5 Clock Sources

The 1322x-LPN supports two primary clock sources for the MC1322x.

3.5.1 Reference Oscillator (24 MHz nominal)

The reference oscillator is the primary source for all internal MC1322x clocks. Figure 3-8 shows the LPB circuitry related to the reference oscillator. The default frequency for the reference oscillator is 24 MHz and the mounted crystal X1 is a 24 MHz device that meets MC1322x specifications. There are two additional options for the module:

- X1 can be replaced by a 13-26 MHz crystal - It must meet MC1322x specifications. In addition, the onboard PLL must be used in this case. The PCB provides for the PLL filter components, but these are not populated. To use a non-standard crystal, the PLL filter components of R5, C4, and C5 must be populated. Also, software must enable use of the PLL for the internal modem clock.
- An external clock source can be supplied as the reference source - This is typically 24 MHz. The frequency must be accurate to ± 40 ppm. The external clock source can be supplied via test point TP86 and C57 (10 pF) must also be installed.

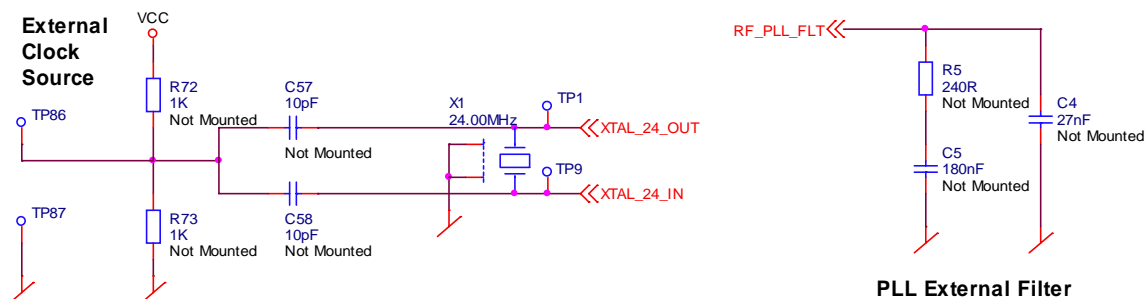

Figure 3-8. Reference Oscillator Related Circuitry

3.5.2 32.768 kHz Crystal Oscillator

Provision is also made for the secondary 32.768 kHz oscillator crystal X2. This oscillator can be used on the MC1322x for a low power accurate RTC timebase and wake-up state machine. The module comes with this crystal and its load capacitors C7 and C12 mounted. Although use of the oscillator is optional, the module is provided ready for use. See [Figure 3-9](#).

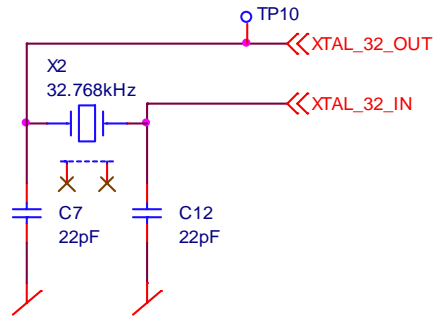

Figure 3-9. 32.768 KHz Oscillator Related Circuitry

3.6 FLASH Memory Recovery Jumpers and Erase

The MC1322x has an onboard serial FLASH that stores the memory image that gets loaded into RAM at boot. If it becomes necessary to change or update the image in FLASH, there are two possible means of doing so:

- JTAG Debug Port - Using the JTAG debug port and the ARM debug tools, the FLASH image can be changed.
- Load new FLASH image via UART1 port -

NOTE

The 1322x-LPN provides a header for UART1 that is NOT buffered for RS232 operation. If users must employ UART1 with the Freescale Test Tool running on a PC, they must provide an appropriate RS232 interface board to connect to a PC serial COM port.

- The Freescale BeeKit IDE suite download provides a software tool called “Test Tool”. This application runs on a PC and can be used with a client running on the MC1322x to test the platform.
- Test Tool also has the capability to load a new image into the FLASH.

NOTE

The FLASH must be cleared before loading a new image.

The 1322x-LPN has two jumper sites designated as J19 and J20 (see [Figure 3-4](#)) that must be used to erase the FLASH:

1. Short Jumper J19 Pin 1 to Pin 2 with a shorting bar, as well as, short Jumper J20 Pin 1 to Pin 2 with a second shorting bar
2. Turn on power, push the reset button, and wait a few seconds.

3. Turn off power and remove the jumper shorts as required.
4. The board is now ready for boot operation.

After the FLASH is erased, the module can be loaded with a new image through the UART1 port using Test Tool. Refer to the *Test Tool User's Guide* as supplied with Test Tool in the BeeKit download.

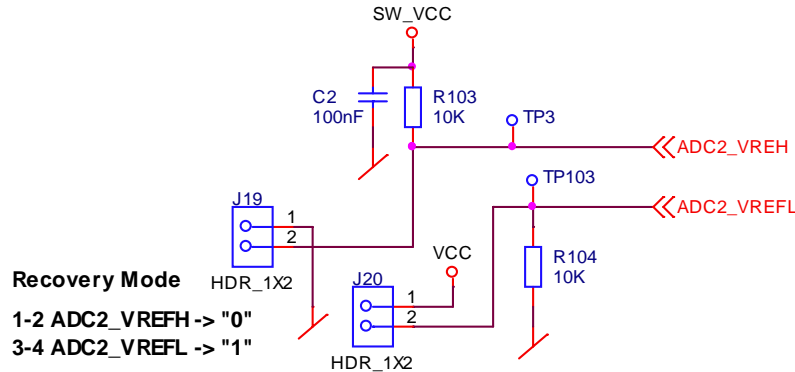

Figure 3-10. FLASH Erase Headers

3.7 Low Power Operation

The 1322x-LPN intended to develop low power operation and applications code. It has been designed to allow low current measurement and support MC1322x low power application needs.

NOTE

It is strongly suggested that the user review the low power considerations described in the *MC1322x Reference Manual*.

3.7.1 Switched VCC for Peripheral Functions

The MC1322x by default does not retain power to its GPIO pads while in low power mode (KBI signals are the exception and do retain power). As a result, GPIO pads should not be driven high while the device is in low power or extraneous current exist. The 1322x-LPN provides a switched VCC for devices connected to the MC1322x while low power mode so that these devices can be disabled when appropriate.

Figure 3-11 shows the switched VCC circuit.

- A P-channel MOSFET is used as a switch to turn SW_VCC ON or OFF as required.
- The MOSFET gate is driven by signal KBI_3 which is always powered and defaults to an output in the high state when in low power. This condition turns off SW_VCC in low power mode.

NOTE

The user must program/control GPIO25 under run (operational) mode. The KBI pins are controlled by the CRM in low power mode; they revert to their GPIO control during normal run mode. As a result, GPIO25 must be programmed as an output and controlled to enable SW_VCC as appropriate for use, or alternatively, GPIO can be programmed as the KBI function under normal operation.

- SW_VCC is provided on the J2 GPIO Pin Header
- SW_VCC also powers U17 the voltage reference for ADC operation.

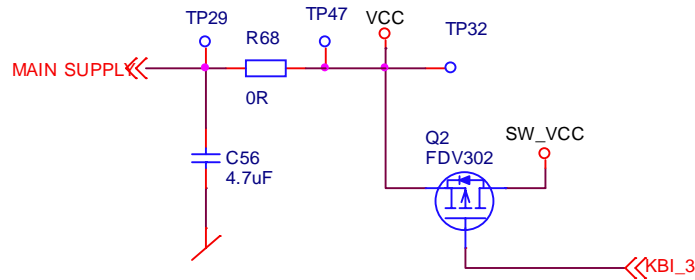

Figure 3-11. Switched VCC for Peripheral Devices

3.7.2 Measuring Current

The 1322x-LPN provides three primary points for current measurement:

- Total current to the board - reference [Figure 3-11](#). R68 can be removed and current can be measured between TP29 and TP47.
- Total current to the MC1322x - reference [Figure 3-7](#). R65 can be removed and current can be measured through jumper J16.
- ADC voltage reference current - reference [Figure 3-12](#). Voltage reference U17 is enabled via J18; current can be measured through this jumper.

3.7.3 Other Low Power Considerations

When designing low power operation, consider:

- Indicator LEDs D1 and D2 are connected to ground not VCC, so as to not put GPIO high during low power mode.
- The GPIO connector (J2) provides access and connectivity to the MC1322x
 - SW_VCC is provided.
 - No peripheral device should pull a GPIO high during low power mode
 - Signal SWITCH1 is connected to KBI_4 and can be used as a wake-up interrupt to the MC1322x. See the CRM chapter of the *MC1322x Reference Manual*.
 - Signal SWITCH2 is connected to KBI_0 and can be used as a wake-up signal from the MC1322x to an external device. See the CRM chapter of the *MC1322x Reference Manual*.
- The UART1 connector (J3) provides direct access to the MC1322x GPIO. If low power mode is enabled and UART1 is connected to an external device, extraneous high leakage current can occur if any of the UART1 signals is driven high.

3.8 User Interfaces

This section provides a summary of the user interfaces.

3.8.1 LEDs, Switches, and Reset

For application interface the 1322x-LPN provides:

- Two red LEDs (D1 and D2) are driven by the MCU and controlled by the software application.
- Two pushbuttons (SW1 and SW2) are connected to the MCU GPIO for software application. Only SW1 has interrupt generation capability, and can be used as an input for low power wake-up.
- Jumper J17 provides a hardware reset capability. Shorting Pin 1 to Pin 2 causes the hardware reset input to be held low and resets the MC1322x.

3.8.2 ADC Voltage References

When using the ADC input channels ADC2 and ADC3 (through J2), consider;

- The ADC high voltage reference ADC2_VREFH is tied to SW_VCC through a resistor. This reference is not absolute and will move as VCC decreases with battery operation.
- A fixed voltage reference for ADC1_VREFH is provided (see [Figure 3-12](#)).
 - The fixed voltage is 1.5 VDC.
 - The LM285M (U17) is programmed via R120 and R121 to provide a constant reference
 - The reference can be enabled via jumper J18. This number can also be used to measure current to the reference circuit.
 - This reference is useful for battery operation where a known, fixed high reference voltage for the ADC is required.

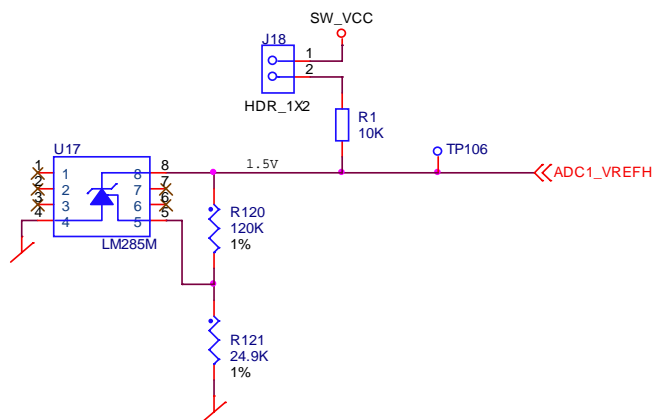

Figure 3-12. ADC Voltage 1.5 VDC Voltage Reference

3.8.3 ARM JTAG Debug Interface Connector

The MC1322x supports connection to a subset of the defined ARM JTAG connector. The JTAG interface is a standard 2.54mm/0.1inch spacing, 20-pin debug interface (J1). The 20-pin connector is clearly separated from the GPIO and UART pin headers and located at the rear side of the module. The 20-pin connector is designated “JTAG” on the silk-screen and has Pin 1 designated for correct plug-in of the development cable.

Table 3-1 shows the device pins that are connected to the associated JTAG header pinouts.

Table 3-1. ARM JTAG 20-Pin Connector Assignments (J1)

Name ¹	Pin #	Pin #	Name
VCC	1	2	VCC
NC ²	3	4	GND
TDI	5	6	GND
TMS	7	8	GND
TCK	9	10	GND
RTCK	11	12	GND
TDO	13	14	GND
RESET ³	15	16	GND
NC	17	18	GND
NC	19	20	GND

¹ NC means No Connect.

² MC1322x does not support separate JTAG reset TRST.

³ VCC through a 100k-ohm pullup.

3.8.4 GPIO Connector

The GPIO connector (J2) is a standard 2.54mm/0.1inch spacing, 12-pin header. The connector provides access to MCU GPIO, two timer GPIOs, two ADC inputs, UART2 port, and the I²C port. Power is also provided on the connector.

- SW_VCC is the main supply voltage. Current draw should be limited to 50 mA.
- Signals SWITCH1 and SWITCH2 are in parallel with onboard switches SW1 and SW2.
- KBI signals are provided through SWITCH1 and SWITCH2 for low power control and interface

Table 3-2. GPIO Connector J2 Pinouts

Pin Number	Name	Function	Notes
1	UART2_RX	UART2 RX data input / GPIO19	UART2 receive data input.
2	UART2_TX	UART2 TX data output / GPIO18	UART2 transmit data output.
3	I2C_SDA	I ² C Bus data / GPIO13	I ² C bus signal SDA. Pull-up to SW_VCC available

Table 3-2. GPIO Connector J2 Pinouts (continued)

4	I2C_SCL	I ² C Bus clock / GPIO12	I ² C bus signal SCL. Pull-up to SW_VCC available
5	TMR3	Timer 3 IO signal / GPIO11	Pin can be used as Counter 3 output or counter input clock.
6	TMR1	Timer 1 IO signal / GPIO9	Pin can be used as Counter 1 output or counter input clock.
7	ADC3	ADC analog input Channel 3/ GPIO33	ADC sample channel can be used by either ADC1 or ADC2.
8	ADC2	ADC analog input Channel 2/ GPIO32	ADC sample channel can be used by either ADC1 or ADC2.
9	SWITCH1	KBI_4 input/ GPIO26	Asynchronous interrupt input can be used as wake-up signal.
10	SWITCH2	KBI_0_HST_WK output/ GPIO22	Can be used as a wake-up indicator output to external device.
11	GND	System ground	
12	SW_VCC	Switched voltage supply	

3.8.5 UART Connector

The UART connector (J3) is a standard 2.54mm/0.1inch spacing, 6-pin header. The connector provides access to the unbuffered UART1 signals. Power is also provided on the connector.

- VCC is the main board supply voltage. Current draw should be limited to 50 mA.
- If low power mode is enabled on the module, all signals on J3 must be not be driven high.
- Signals are unbuffered for RS232; an adaptor board is needed to talk to a PC serial COM port

Table 3-3. UART Connector J3 Pinouts

Pin Number	Name	Function	Notes
1	UART1_RX	UART1 RX data input / GPIO19	UART2 receive data input.
2	UART1_TX	UART2 TX data output / GPIO18	UART2 transmit data output.
3	UART1_CTS	UART1 Clear to Send output / GPIO16	UART1 CTS control output.
4	UART1_RTS	UART1 Request to Send input / GPIO17	UART1 RTS control input.
5	GND	System ground	
6	VCC	Main voltage supply	

3.8.6 Jumper Selection

Table 3-4 lists all the possible jumper selections for the 1322x-LPN. The jumpers available on the board are:

- J16 - used to measure MC1322x current
- J17 - used to reset MC1322x
- J18 - used to enable 1.5V reference
- J19, J20 - used to recover/clear FLASH. See Table 3-4.

Table 3-4. LPB Jumper Selection

Pin Header	Pin Number Connection	Description	Default Setting
J16	1-2	Connect to ammeter to measure MC1322x current. R65 should be removed	Not mounted. Can be mounted for operation w/o R65
J17	1-2	Connect to reset MC1322x	Not mounted
J18	1-2	Connect to enable 1.5V reference	Not mounted
J19, J20	1-2, 1-2	Connect both to recover/clear FLASH. See Section 3.6, "FLASH Memory Recovery Jumpers and Erase"	Not mounted

Chapter 4 Schematic, Board Layout, and Bill of Materials

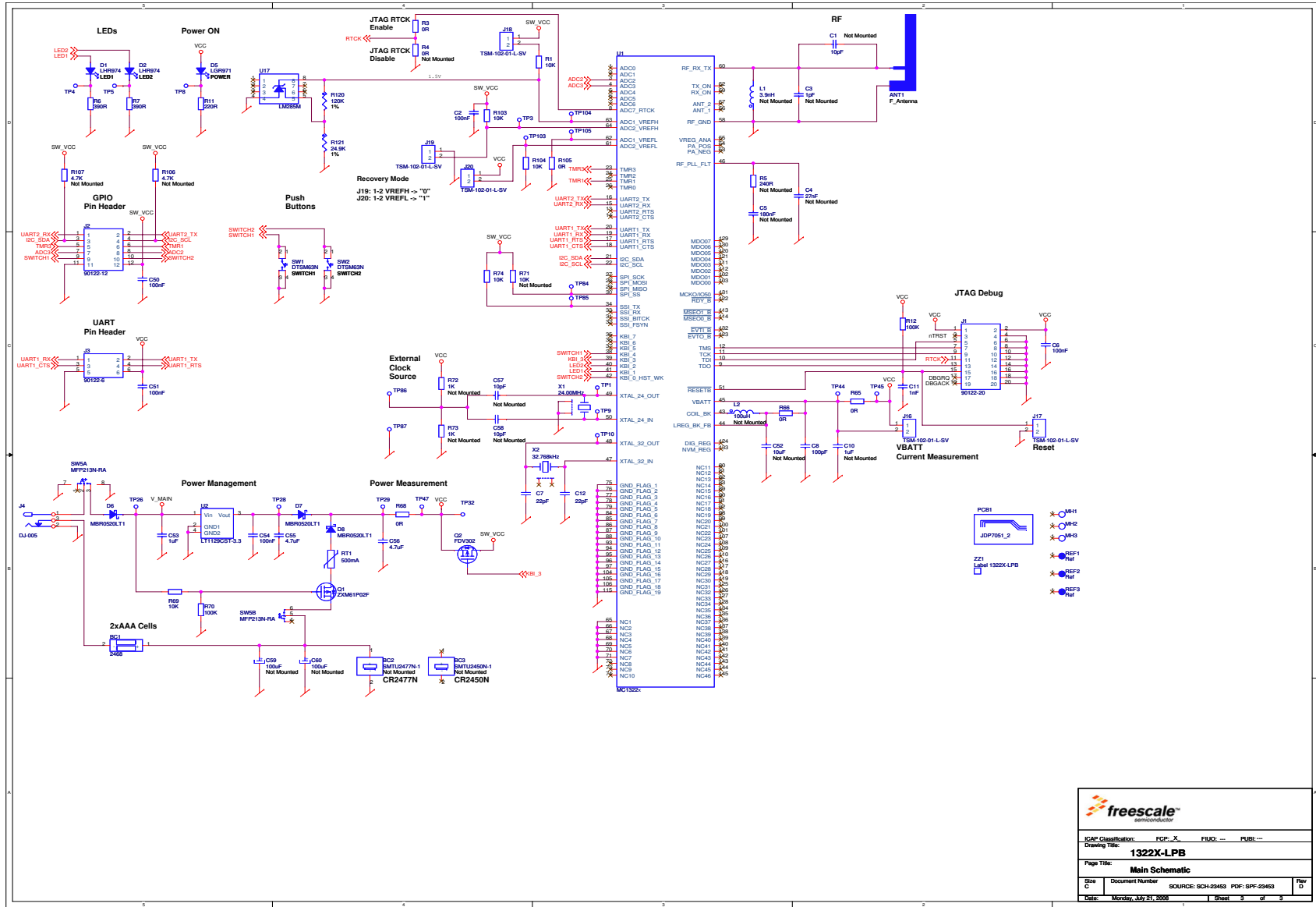

Schematic, Board Layout, and Bill of Materials

Figure 4-1. 1322X-LPN Schematic

ICAP Classification: FCP: X FILM: -- PUB: --			
1322X-LPB			
Main Schematic			
Size C	Document Number	SOURCE: BCH-23453	PDF: SFF-23453
Rev 1	Rev D	Issue: Monday, July 21, 2008	Sheet 3 of 3

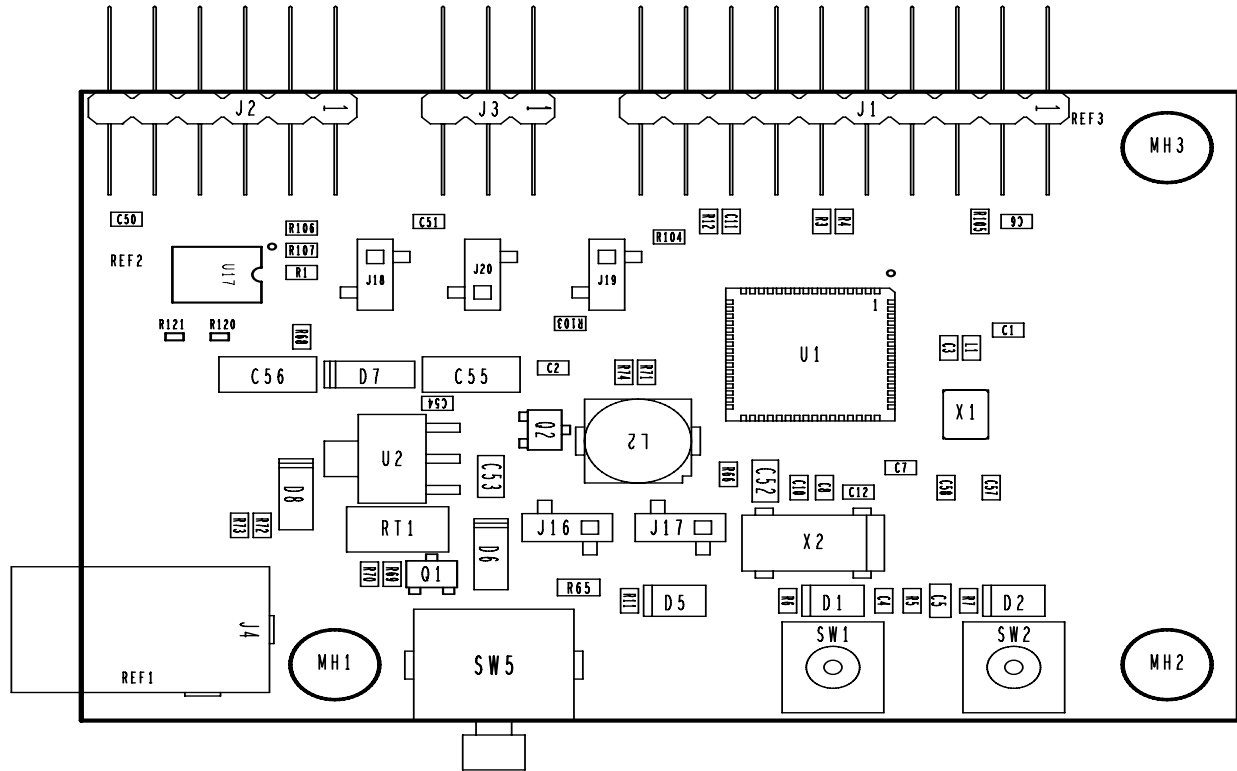

Figure 4-2. 1322x-LPN PCB Component Location (Top View)

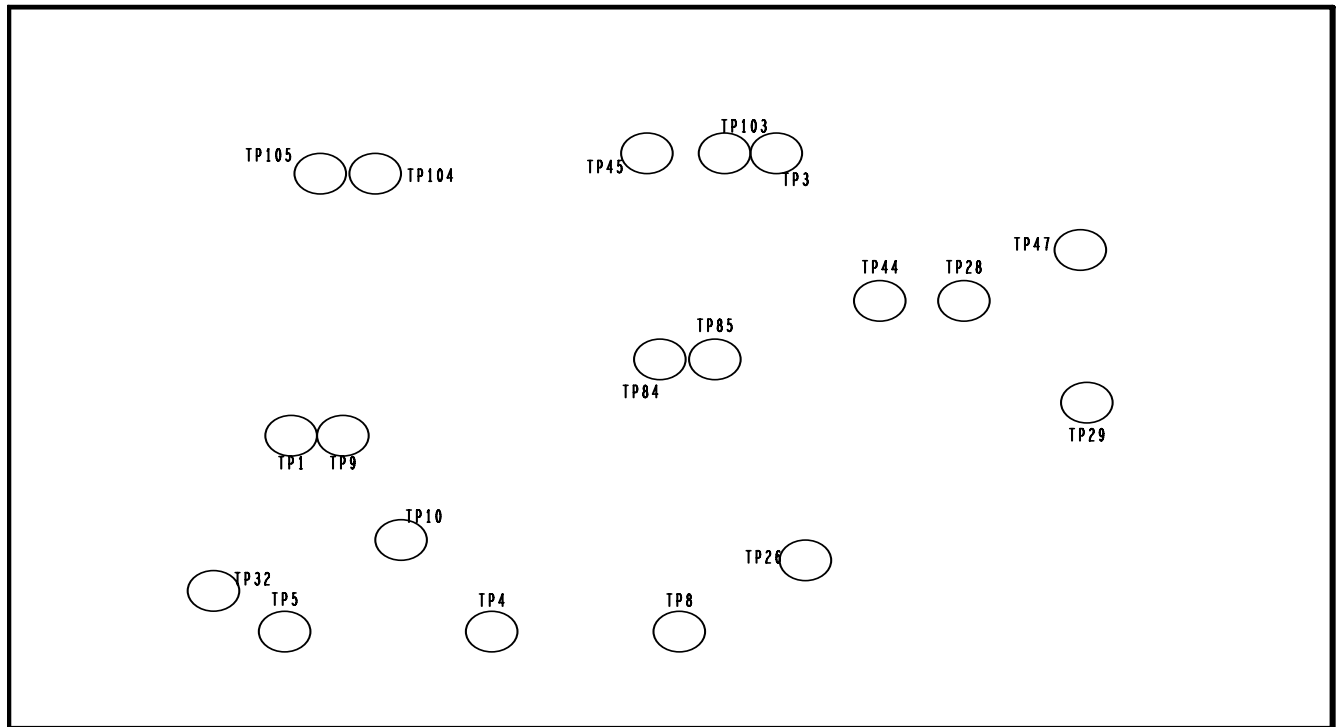

Figure 4-3. 1322x-LPN PCB Test Points (Bottom View)

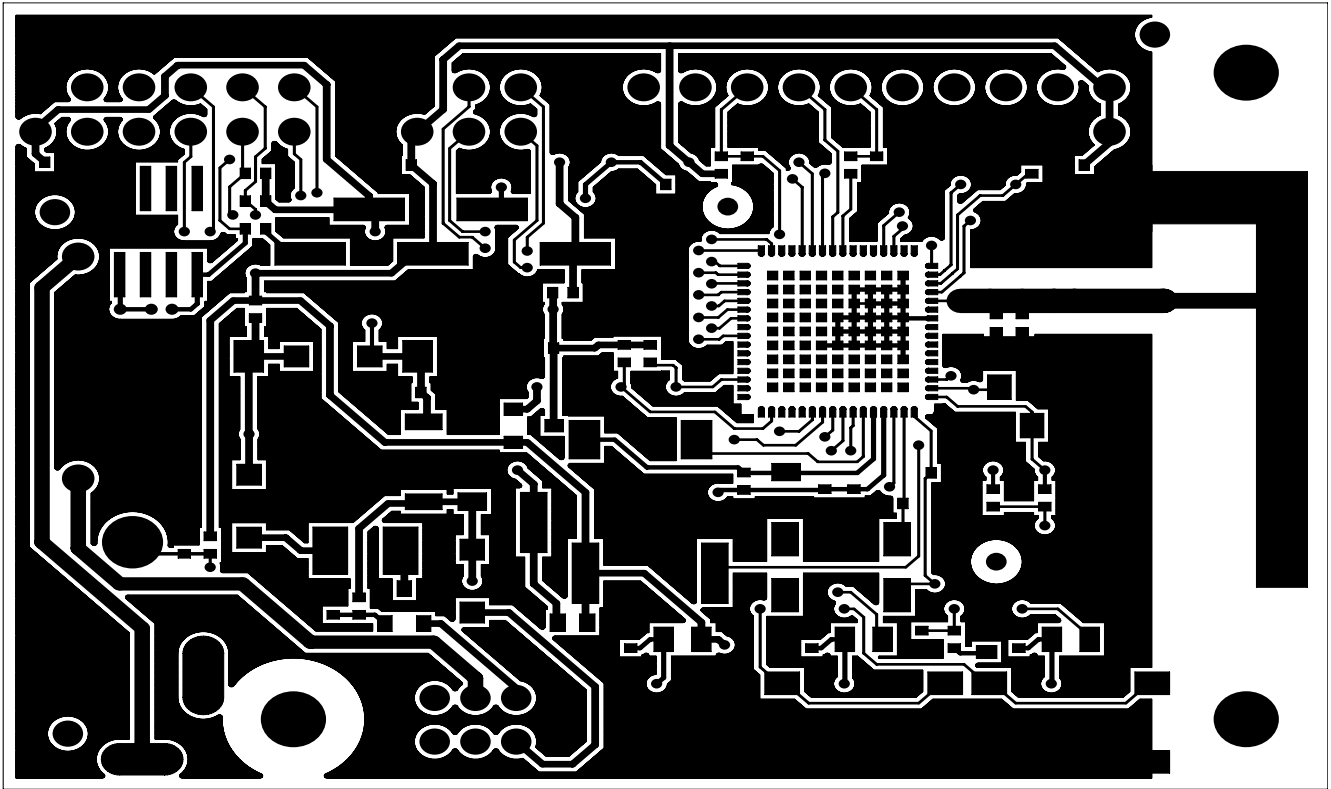

Figure 4-4. 1322x-LPN PCB Layout (Top View)

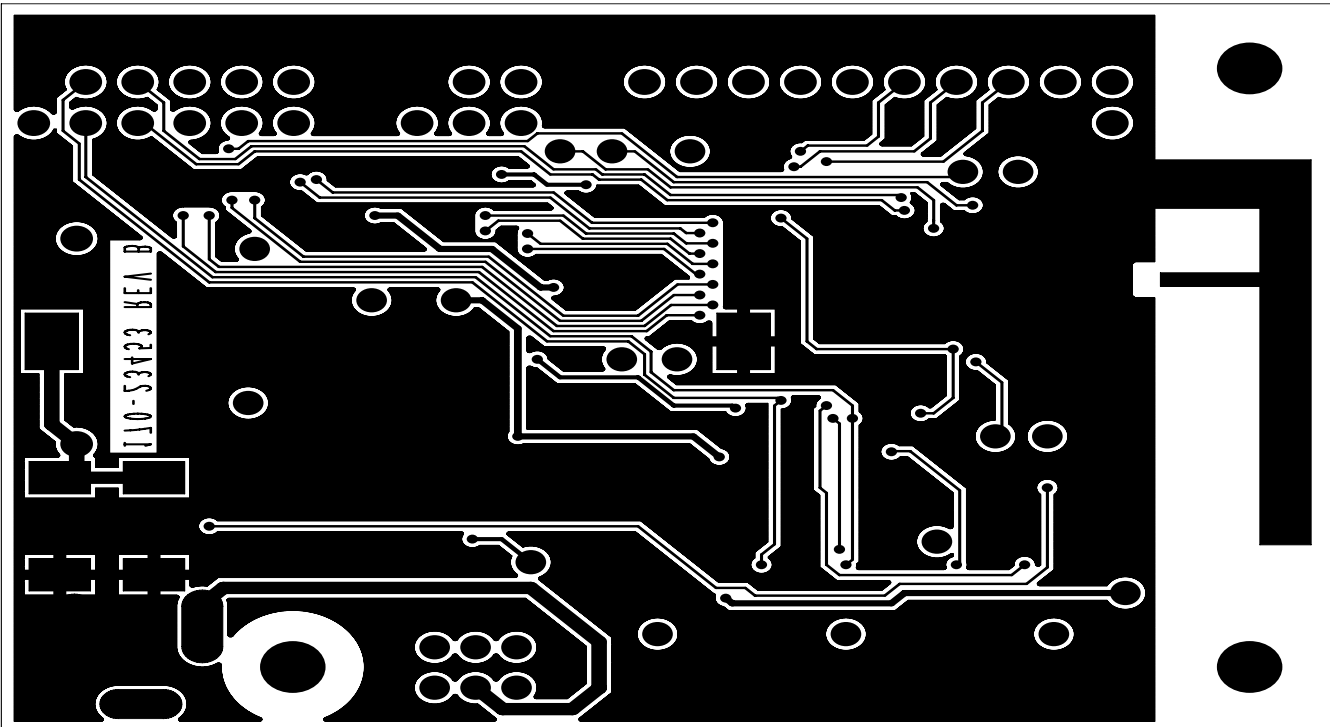

Figure 4-5. 1322x-LPN PCB Layout (Bottom View)

Table 4-1. Bill of Materials

Qty	Reference	Description	Value	Voltage	Power	Tolerance	Mfg	Manufacturer Part Number
1	ANT1	PCB F ANTENNA					NOT A PART	NOT A PART
1	BC1	PCB Battery Holder 2xAAA					Keystone	2468
0	BC2	Surface mount coin cell holder CR2477N					Reneta	SMTU2477N-1
0	BC3	Surface mount coin cell holder CR2450N					Renata	SMTU2450N-1
0	C1,C57,C58	Ceramic Capacitor COG	10pF	50V		5%	Murata	GRM1555C1H100JZ01
5	C2,C6,C50,C51,C54	Ceramic Capacitor X5R	100nF	10V		10%	Murata	GRM155R61A104KA01D
0	C3	Ceramic Capacitor COG	1pF	50V		0.25pF	Murata	GRM1555C1H1R0CZ01D
0	C4	Ceramic Multilayer Capacitor X7R	27nF	10V		5%	Vishay	VJ0402Y273JXQCW1BC
0	C5	Ceramic Multilayer Capacitor X7R	180nF	16V		5%	Vishay	VJ0603Y184JXJCW1BC
2	C7,C12	Ceramic Capacitor COG	22pF	50V		5%	Murata	GRM1555C1H220JZ01J
1	C8	Ceramic Capacitor COG	100pF	50V		5%	Murata	GRM1555C1H101JZ01
0	C10	Ceramic Capacitor X5R	1uF	6.3V		10%	Murata	GRM155R60J105KE19B
1	C11	Ceramic Capacitor X7R	1nF	50V		10%	Murata	GRM155R71H102KA01D
0	C52	Ceramic Capacitor for smoothing X5R	10uF	10V		10%	Murata	GRM21BR61J106KE19L
1	C53	Ceramic Multilayer Capacitor X7R NoPb	1uF	16V		15%	Murata	GRM21BR71C105
2	C55,C56	Ceramic Multilayer Capacitor X5R	4.7uF	16V		15%	Phycomp	2222 781 13672
0	C59,C60	Low ESR Tantal Capacitor	100uF	16V		+/-10%	AVX	TPSD107K016R150
2	D1,D2	SMD Red toped	LHR974				OSRAM	Q62702P5182
1	D5	SMD Green toped	LGR971				OSRAM	Q65110P5179
3	D6,D7,D8	SMD Power Schottky Rectifier		20V			On Semi	MBR0520LT1G

Table 4-1. Bill of Materials (continued)

1	J1	Dual Row Right Angle pin header 0.38um gold					Molex	90122-0770
1	J2	Dual Row Right Angle pin header 0.38um gold					Molex	90122-0766
1	J3	Dual Row Right Angle pin header 0.38um gold					Molex	90122-0763
1	J4	DC Power Jack PCB, 2mm					Taitek	2DC-0005-D100
5	J16,J17,J18,J19,J20	Single Row Straight Pin Header SMD					Samtec	TSM-102-01-L-SV
0	L1	HF Chip coil	3.9nH			5%	Murata	LQG15HS3N9S02D
0	L2	SMD power inductor	100uH			20%	TDK	SLF6028T-101MR42-PF
1	PCB1							JDP7051_2
1	Q1	P-channel MOSFET		20V			Zetex	ZXM61P02F
1	Q2	Digital P-Channel FET		25V			Fairchild	FDV302P
1	RT1	Polyswitch Overcurrent Protection Device	500mA	13.2V			Tyco Electronics	microSMD050F
5	R1,R69,R74,R103,R104	Fixed resistor RC31	10K	50V	0.063 W	2%	Philips	2322 705 50103
1	R65	Fixed resistor RC21	0R	50V	0.063 W	5%	Philips	2322 702 91002
4	R3,R66,R68,R105	Fixed resistor RC31	0R	50V	0.063 W	2%	Philips	2322 705 91002
0	R4	Fixed resistor RC31	0R	50V	0.063 W	2%	Philips	2322 705 91002
0	R5	Fixed resistor RC31	240R	50V	0.063 W	2%	Philips	2322 705 50241
2	R6,R7	Fixed resistor RC31	390R	50V	0.063 W	2%	Philips	2322 705 50391
1	R11	Fixed resistor RC31	220R	50V	0.063 W	2%	Philips	2322 705 50221
2	R12,R70	Fixed resistor RC31	100K	50V	0.063 W	2%	Philips	2322 705 50104
0	R71	Fixed resistor RC31	10K	50V	0.063 W	2%	Philips	2322 705 50103

Table 4-1. Bill of Materials (continued)

0	R72,R73	Fixed resistor RC31	1K	50V	0.063 W	2%	Philips	2322 705 50102
0	R106,R107	Fixed resistor RC31	4.7K	50V	0.063 W	2%	Philips	2322 705 50472
1	R120	RES MF 120K 1/16W 1% 0402	120K		1/16W	1%	KOA SPEER	RK73H1ETTP1203F
1	R121	RES MF 24.9K 1/16W 1% 0402	24.9K		1/16W	1%	KOA SPEER	RK73H1ETTP2492F
2	SW1,SW2	SMD Tact Switch 2.6N (7.0mm)					Diptronic	DTSM-63R-V-B
1	SW5	Miniature Slide Switch 2 pole					Knitter- Switch	MFP213N-RA
1	U1	ZigBee Wireless Transceiver and ARM7 processor					Freescale	MC1322x
1	U2	LDO voltage regulator 3V3					Linear Technology	LT1129CST-3.3
1	U17	IC VREG ADJ 1.24-5.3V 20MA SOIC8					National Semi	LM285M/NOPB
1	X1	Crystal SMD	24.00MHz			+/-10ppm	NDK	EXS00A-CS02020 (24MHz NX3225SA) (for OA/AV and Bluetooth)
1	X2	Crystal SMD	32.768kHz			+/-20ppm	Abracon	ABS25-32.768-12.5-2-T